



Standard Test Method for Free-Swelling Index of Coal¹

This standard is issued under the fixed designation D720/D720M; the number immediately following the designation indicates the year of original adoption or, in the case of revision, the year of last revision. A number in parentheses indicates the year of last reapproval. A superscript epsilon (ϵ) indicates an editorial change since the last revision or reapproval.

This standard has been approved for use by agencies of the U.S. Department of Defense.

^{ε1} NOTE—Added research report footnote to the Appendix editorially in March 2015.

1. Scope

1.1 This test method² is a small-scale test for obtaining information regarding the free-swelling properties of a coal. The results may be used as an indication of the caking characteristic of the coal when burned as a fuel. This test is not recommended as a method for the determination of expansion of coals in coke ovens.

1.2 **Warning**—Breathing of asbestos dust is hazardous. Asbestos and asbestos products present demonstrated health risks for users and for those with whom they come into contact. In addition to other precautions, when working with asbestos-cement products, minimize the dust that results. For information on the safe use of chrysotile asbestos, refer to, *Safe Use of Chrysotile Asbestos: A Manual on Preventive and Control Measures*.³

1.3 The values stated in either SI units or inch-pound units are to be regarded separately as standard. The values stated in each system may not be exact equivalents; therefore, each system shall be used independently of the other. Combining values from the two systems may result in non-conformance with the standard.

1.4 *This standard does not purport to address all of the safety concerns, if any, associated with its use. It is the responsibility of the user of this standard to establish appro-*

priate safety and health practices and determine the applicability of regulatory limitations prior to use.

2. Referenced Documents

2.1 *ASTM Standards*:⁴

- D2013 Practice for Preparing Coal Samples for Analysis
- E691 Practice for Conducting an Interlaboratory Study to Determine the Precision of a Test Method

3. Significance and Use

3.1 This test method, in addition to indicating the caking properties of a coal when burned as a fuel, can be used to give a broad indication of the degree of oxidation of a coal.

4. Apparatus

4.1 This test method can be made with either electric or gas heating. When using electric heating, the results obtained must be the same as those obtained when using the gas heating method. The apparatus common to both electric and gas methods shall consist of the following:

4.1.1 *Crucible*, translucent silica, low-form, with a flat, close-fitting silica ring-handle lid and an extra pierced lid for use in determining the crucible temperature, conforming to the following requirements:

Weight, g	11.0 to 12.75
External height, mm	26 ± 0.5
External diameter at top, mm	41 ± 0.75
Internal diameter at base, min, mm	11
Capacity (approximate), cm ³	17

4.1.2 *Sight Tube*, as shown in Fig. 1, for viewing the coke buttons so that the effect of parallax will be eliminated. Make the tube of any rigid and preferably opaque material and support vertically on a ring stand.

4.1.3 *Thermocouple and Potentiometer*.

4.1.4 *Weight*, 500 g.

4.2 The electric apparatus shall consist of the following:

⁴ For referenced ASTM standards, visit the ASTM website, www.astm.org, or contact ASTM Customer Service at service@astm.org. For *Annual Book of ASTM Standards* volume information, refer to the standard's Document Summary page on the ASTM website.

¹ This test method is under the jurisdiction of ASTM Committee D05 on Coal and Coke and is the direct responsibility of Subcommittee D05.15 on Metallurgical Properties of Coal and Coke.

Current edition approved Jan. 1, 2015. Published January 2015. Originally approved in 1943. Last previous edition approved in 2010 as D720 – 91 (2010). DOI: 10.1520/D0720/D0720M-15E01.

² This test method is an adaptation of the Crucible Swelling Test for Coal of the British Standards Institution. For information concerning the experimental work on which this adaptation is based, see paper by Ostborg, H. N., Limbacker, H. R., and Sherman, R. A., "An Experimental Investigation of the British Standard Method for the Crucible Swelling Test for Coal," *Proceedings, Am. Soc. Testing Mats.*, Vol 42, 1042, p. 851. See also a paper by Selvig, W. A., and Ode, W. H., "An Investigation of a Laboratory Test for Determination of the Free-Swelling Index of Coal," *U.S. Bureau of Mines Report of Investigation 4238*, Revision of R. I. 3989, 1948.

³ *Safe Use of Chrysotile Asbestos: A Manual on Preventive and Control Measures* Chrysotile Institute 1200, McGill College Suite 1640 Montreal, Quebec Canada H3B 4G7

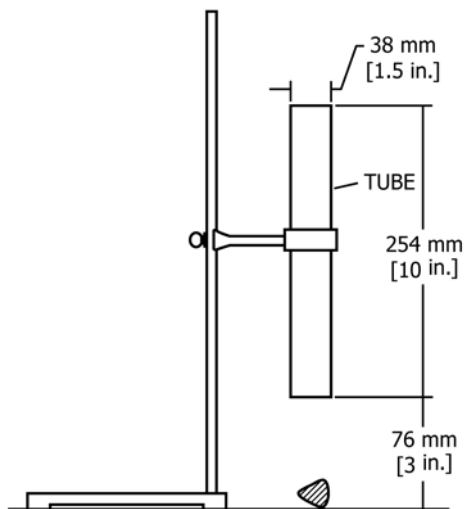

FIG. 1 Sight Tube

4.2.1 *Furnace*, consisting of a base, a heating element, and a chimney. The unit is shown in Fig. 2.

4.2.1.1 *Chimney*—Fig. 2 shows the chimney design. Make the unit from firebrick and coat with firebrick bonding mortar. Maintain the chimney under compression by a sheet-metal envelope (Fig. 2) to prevent cracking. Make the envelope in four pieces, each piece covering a corner. The pieces shall overlap at the center of the flat faces and be held together by bolts and springs. Place two layers of asbestos paper between

the chimney brick and the envelope. Cut two grooves in the upper inside chimney walls to accommodate the crucible support. In cases in which the furnace is located in a drafty area, it is advisable to shield the chimney to prevent large fluctuations in furnace temperature.

4.2.2 *Crucible Support*—A convenient crucible support consists of a cradle support made from nickel-chromium wire suspended from a metal ring. The height of the support inside the furnace can be adjusted by loosening the two screws that hold the wire legs of the support in place.

4.2.3 *Electric Controls*, consisting of a rheostat, an a-c ammeter, and two timers. These components shall conform to the following specifications:

Ammeter	a-c, 0 to 10-A range
Rheostat	100 W, 10 Ω
Variable transformer	7.4 A, 120 V
Timer	mechanical, 0-5 min minimum span, with a hold position, and electrical contact closed during timing cycle

4.2.3.1 One timer shall actuate the rheostat, at a predetermined setting, after 1½ min of operation. Preset the rheostat to reduce the rate of heating of the furnace so that a temperature of $820 \pm 5^\circ\text{C}$ [$1508 \pm 9^\circ\text{F}$] is achieved at the end of 2½ min. A variable transformer is desirable for establishing the input voltage to the furnace.

4.3 The gas apparatus shall consist of the following:

4.3.1 *Burner Assembly*—A gas burner with a grid of external diameter, 30 to 42 mm [1.18 to 1.65 in.], a draft shield, and a

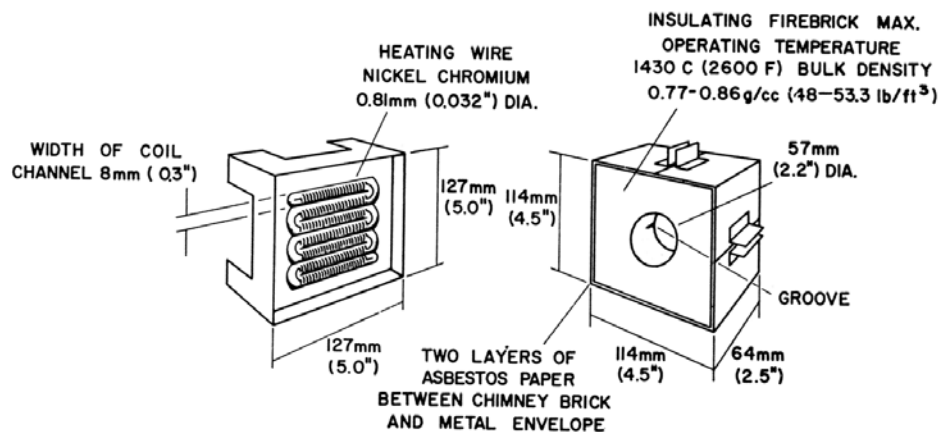

ELECTRIC HEATER (750 WATTS 115 VOLTS)

CHIMNEY

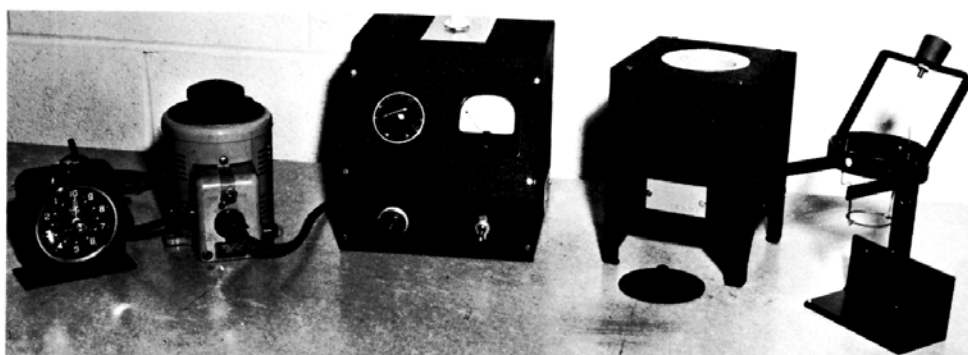

FIG. 2 Furnace Base and Chimney